

## Rotary Atomizer Type F100

*for atomization  
of fluid feeds in  
spray drying*

- Double helical gear drive
- For abrasive and non-abrasive feeds
- Heavy duty design
- Patented atomizer wheels

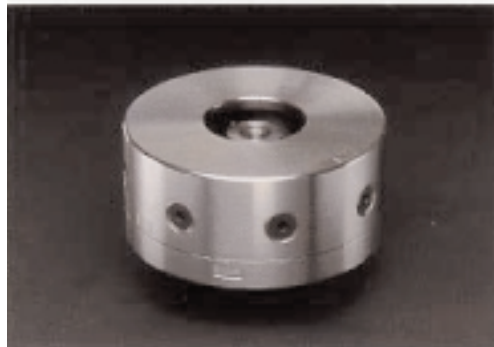
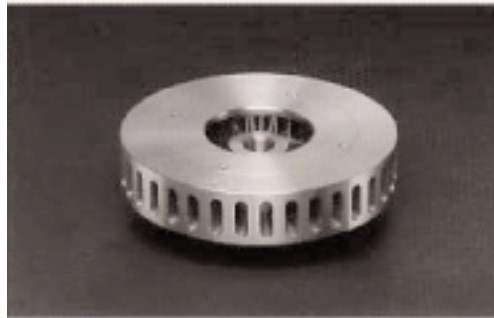

# Rotary Atomizer, Type F100

## The Atomizer Drive

The atomizer drive consists of two parts. The upper part comprises the gearbox, motor, and its support. The atomizer is powered by a 2-pole vertical flange motor mounted directly on the gearbox. The power is transmitted from the motor to the gearbox input shaft via a flexible coupling. The lower part of the atomizer comprises the support for the spindle bearings, feed pipe bracket and the conical protective skirt. The spindle runs in special high speed, single row, radial ball bearings. The drive is designed according to the flexible spindle concept, so that irregularities in feed rate and other minor imbalances in the atomizer wheel can be compensated without spindle and bearing damage. The atomizer monitoring system comprises:

- Low oil flow alarm.
- High oil level alarm.
- Flooding alarm as protection against feed leakage on the supporting plate.
- Ammeter and running hour meter installed in the spray dryer control panel to indicate operating performance.
- Spindle vibration alarm as protection against excessive vibration conditions (optional extra for heavy duty applications).

- Tachometer to register variable spindle speed adjusted by control of frequency converter (optional extra)

The atomizer parts exposed to feed comply with US-3A and similar national sanitary directives.

## The Atomizer Wheel

The F100 atomizer can operate with either a channel type (for non-abrasive feeds) or an insert type (for abrasive feeds) wheel of 210 mm diameter.

The channel wheel is equipped with either 24 low or 36 high straight channels or 16 low or high curved channels. The straight channel wheels are used in cases where there are no specific requirements of bulk density in the final product. The curved channel wheels produce higher bulk density (higher than with a straight channel wheel) in case of organic products.

The patented design of insert type wheel consists of 8 inserts. The wheel parts exposed to feed are abrasion-resistant and easily replaceable. The conical inserts and the bottom plate of the stainless steel wheel are made from alumina or advanced ceramic material.

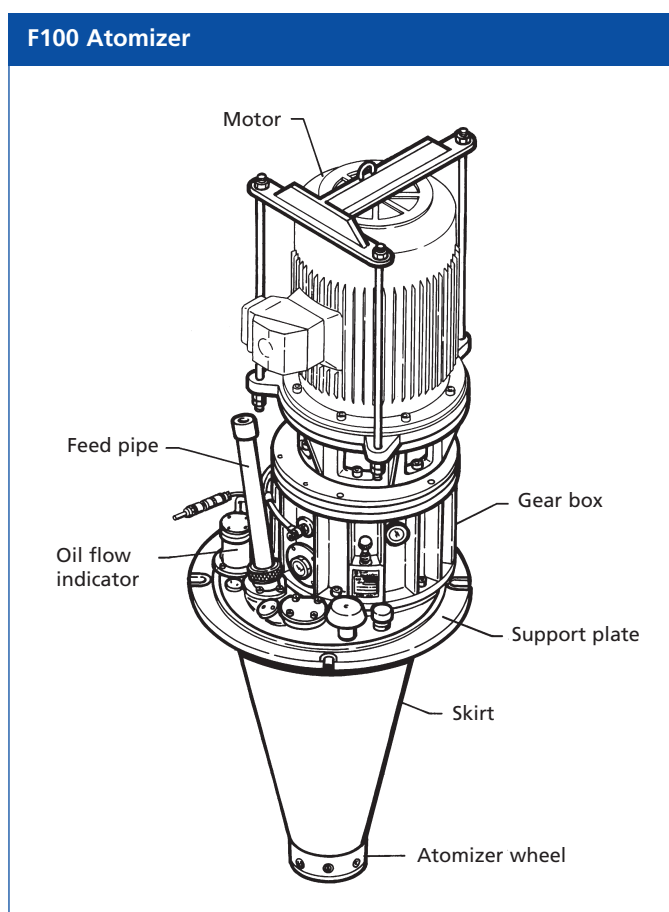

## Specification

Wheel speed range:	7,250 - 17,750 rpm
Feed rate:	max. 17 t/h
Feed pipe:	1" BSP
Cooling air pipe:	1 1/2" BSP
Weight (exclusive of motor):	495 kg
Nominal power consumption:	max. 75 kW
Gearbox:	double helical