

# Systematic Cleaning

with the CIP-Unit – Type SRS – for all applications



Process Equipment

**GEA Tuchenhagen**

# Systematic Cleaning

The CIP unit, type SRS comprises in a basic unit all functions required for a reliable cleaning process such as CIP supply, chemical dosing, heating, monitoring and control. The tanks being placed apart from the basic unit serve solely for detergent supply. The modular structure of the CIP unit gives the necessary flexibility for an adaptation to capacity and equipment requirements of the process. The process independent system design allows free choice of the required cleaning process.

## Single-Use Cleaning

Basic Unit

Tanks

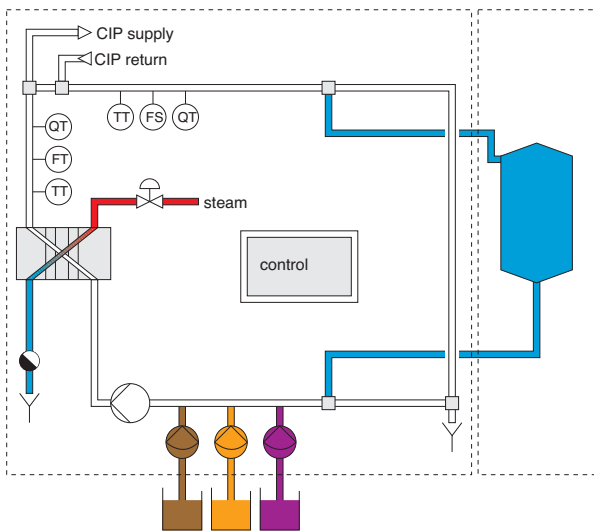

### Application:

- at risk of cross contamination
- high soil load
- low circulation volumes

The unit designed for single-use cleaning (freshly prepared CIP media) consists of the basic unit and one buffer tank (for fresh and hot water only).

For a reduction of water and energy consumptions, it is possible to recover cleaning solutions of a low soil content in separate tanks for a later re-use.

### Design features

- compact design
- little space required
- simple installation, maintenance and commissioning
- modular structure built up with function blocks
- Factory tested
- Flexible system, easy to add more tanks
- Suitable for validation
- Single-use application also possible with CIP recovery systems
- Design of basic unit is independent of size and type of plant to be cleaned
- Low investment cost

## CIP Recovery

Basic Unit

Tanks

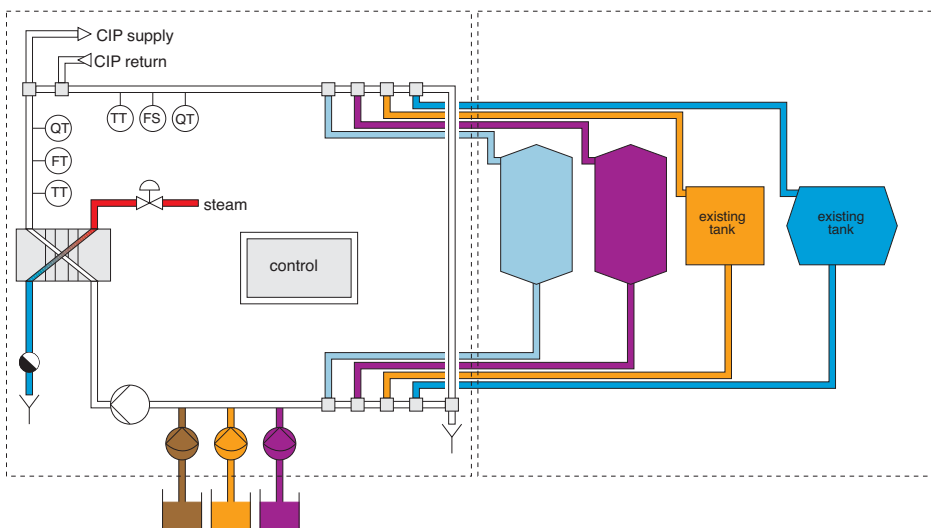

### Application:

- High circulation volumes
- Frequent cleaning
- Low soil load

The basic unit can be easily expanded to a recovery system by the addition of further valves and tanks. Its use for single use cleaning is not affected, giving optimum flexibility.

## CIP Control System

The CIP unit is equipped with a Programmable Logic Controller, (PLC) Siemens S7 that assumes simple data exchange with other plant parts.

On request, the control system may be equipped with special interface modules that allow the communication with external control systems or the data output on a printer.

The operator dialogue is menu-controlled and contains selectable standard menus for:

- program operation
- program overview
- parameter input/output
- controller operation (bar chart)
- measured value display (bar chart)
- measured value archive (curve)
- operation and error log

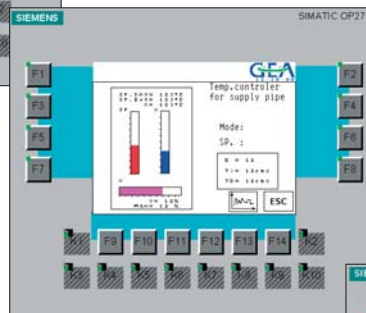
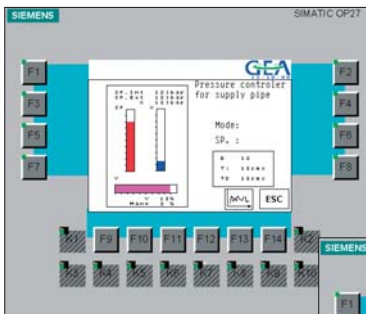

The measured value archives allow for an optimal configuration of the process:

- Detergent flush-outs
- Cleaning times
- Concentration of cleaning media
- Optimisation of water consumptions



Standard functions depending on the degree of system equipment:

- Error display, incl. message of the error cause
- Refilling the tank
- Heating in circulation
- Temperature control
- Dosing control via conductivity

The controller's measuring value menus are used for display and operation of all necessary parameters.

- adjustment of limit values
- Setpoint adjustment
- Adjustment of control parameters
- Changing the operating mode

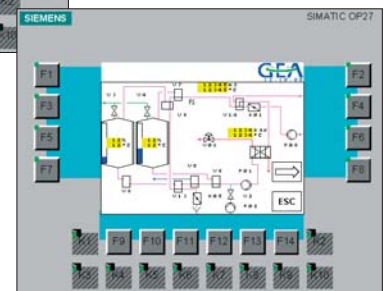

## Sizes and capacities

Capacity range:

- up to 8 m<sup>3</sup>/h DN 40
- up to 18 m<sup>3</sup>/h DN 50
- up to 30 m<sup>3</sup>/h DN 65
- up to 50 m<sup>3</sup>/h DN 80

The size of the CIP circuit defines the flow rate of the supply pump and the capacity of the integrated heat exchanger. Steam consumption from 300 kg up to 1,500 kg steam/h. After passing the integrated heat exchanger once, the temperature is increased by approx. 15 to 20° C.

## Equipment and technical data of the basic unit

- Supply pump
- Dosing pump
- Control system
- Complete pipe system mounted on base frame ready for connection
- Material of parts in contact with liquids: 1.4404 / 1.4571
- Surface quality of parts in contact with liquids:  $Ra \leq 1.6 \mu\text{m}$
- Material of seals in contact with liquids: EPDM
- Dimensions: 1,000 x 1,900 x 2,000 mm ( W x L x H )
- Weight: 600 to 800 kg (depending on the model size)
- Design according to the pressure equipment directive

## Control

- Power supply 400V
- PLC, Siemens S-7
- Design acc. to VDE/EN
- Separate installation of the PLC and power supply unit, incl. motor control centre
- Sufficient memory space provided for the actuation of route valves and pumps

## Optional equipment

- Plate heat exchanger for hot cleaning
- Feedback of remote control valves
- Frequency converter for CIP supply pump, if different CIP circuits exist
- Expandable by up to three dosing pumps
- Integration of peripheral components
- Heat exchanger with increased capacity
- Tubular heat exchanger

## Mobile CIP unit

- return pump

## Additional equipment for control system

- Operating panel, Siemens
- Interface modules
- Printer

## Software (additional programs)

- Tank CIP program
- Pipe CIP program
- CIP program for components

## Additional requirements

- automatic emptying of the system
- Orbital welding
- Weld documentation
- Surface quality inside  $Ra \leq 0.8 \mu\text{m}$

Manual operating mode available on request.



Process Equipment

GEA Tuchenhausen GmbH

Am Industriepark 2-10, 21514 Büchen, Germany

Phone +49-4155 49-0, Fax +49-4155 49-2428

sales.geatuchenhausen@geagroup.com, www.tuchenhausen.com